

High-Pressure Solutions
Since 1974



Pump Presentation

Maximum Lifetime

- made from high-quality materials with long life time
- pump head made as a single forged component, thus less seals
- compact, low power to weight ratio
- easy to install
- no coatings, solid ceramic plungers
- low number of parts
- easily convertible to other flowrates within power rating
- split gearbox through crankshaft and pinion shaft bearing
- interchangeable parts in a modular system



UNIQUE KAMAT FEATURES



Simple Service

- all wearing parts quickly accessible without pump head removal
- no lifting devices necessary for maintenance
- easy to maintain due to interchangeability and simplicity of parts
- seal service in 1h

Low Filter Requirements

- pump can be operated with „dirty“ fluids, up to 350µm filtration
- all fluid end parts stainless, no coatings



Operational Reliability

- reliable oil pressure supply, specially designed for VFD-service
- fluid end design allows very low NPSHr
- optimised gear case for little vibration and noise
- pumps are supported world wide
- **100% Made in Germany, including raw materials**

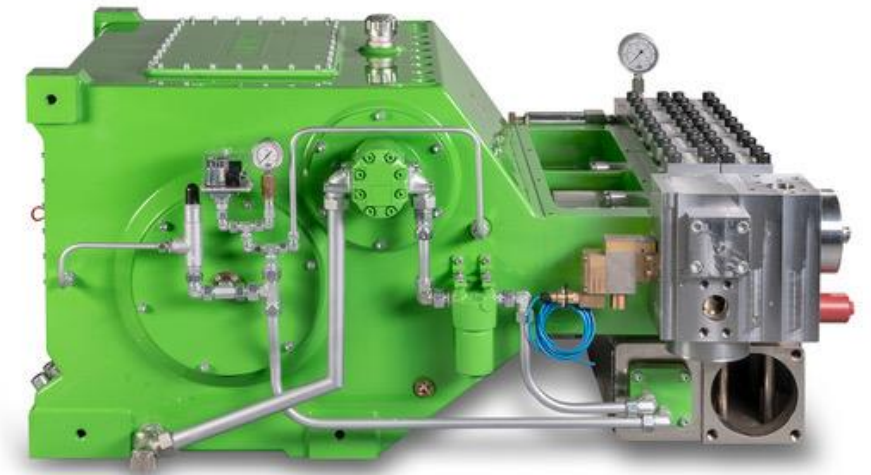

QUINTUPLEX PLUNGER PUMP K 80000 MC - 5G

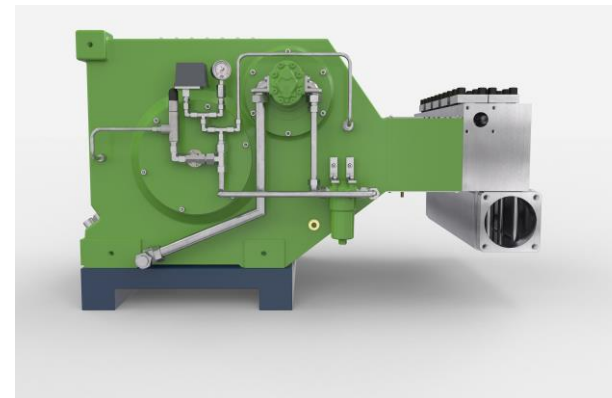
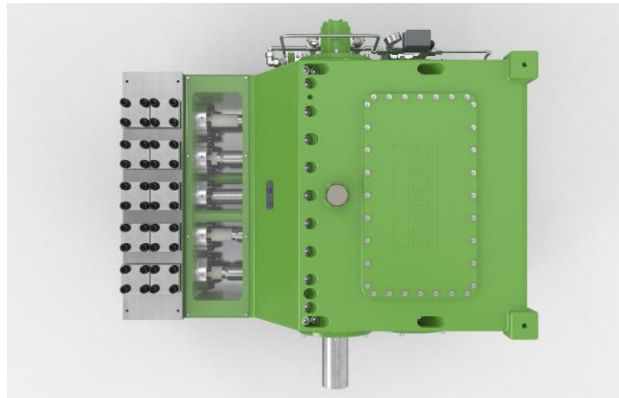
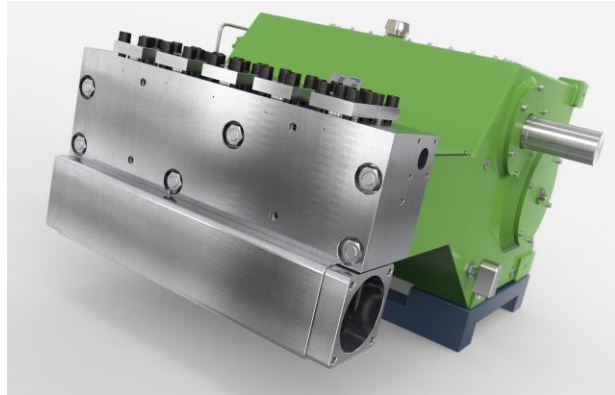

TRIPLEX MC / MCH - 3G PUMP

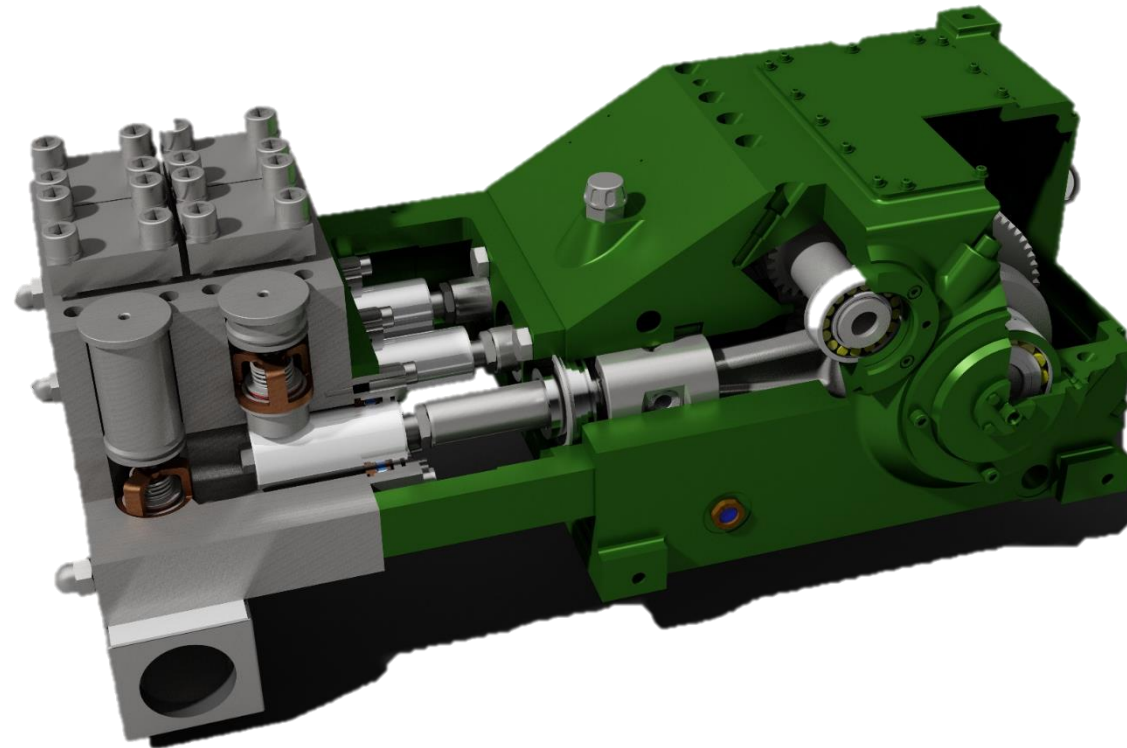

© KAMAT 2020

TRIPLEX MC / MCH - 3G PUMP

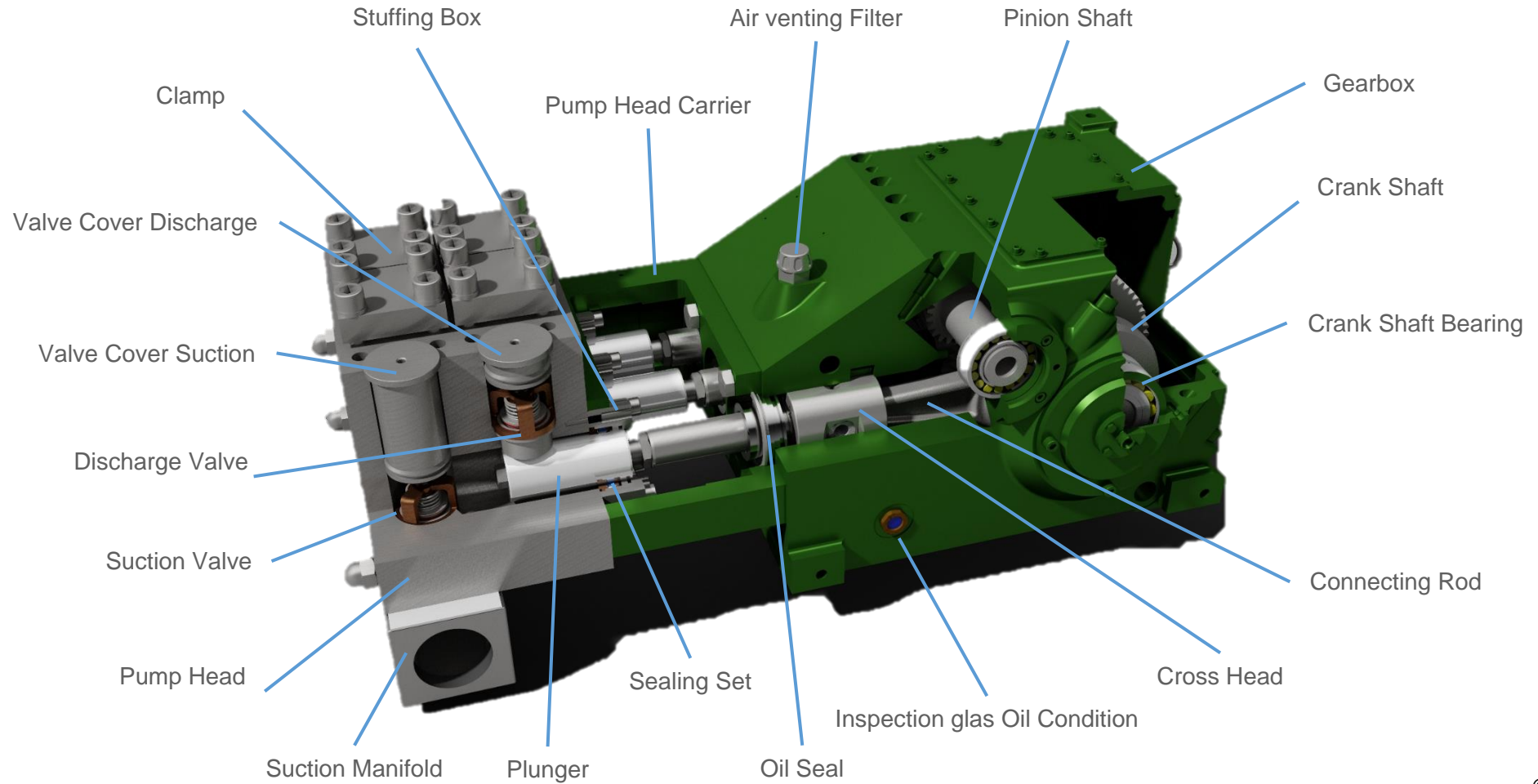

© KAMAT 2020

KAMAT Integrated Gear Reductions

- are space saving
- are self adjusting
- are silent
- have a long bearing life
- run cool

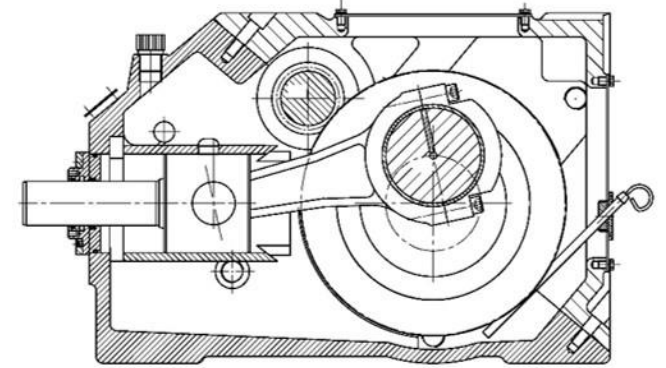

KAMAT Integrated Gear Reductions

- maintenance without draining the oil
- maintenance without removing the pump head
- double helical gears for long bearing lifetime, silent, cool operation
- durable drop-forged crankshaft

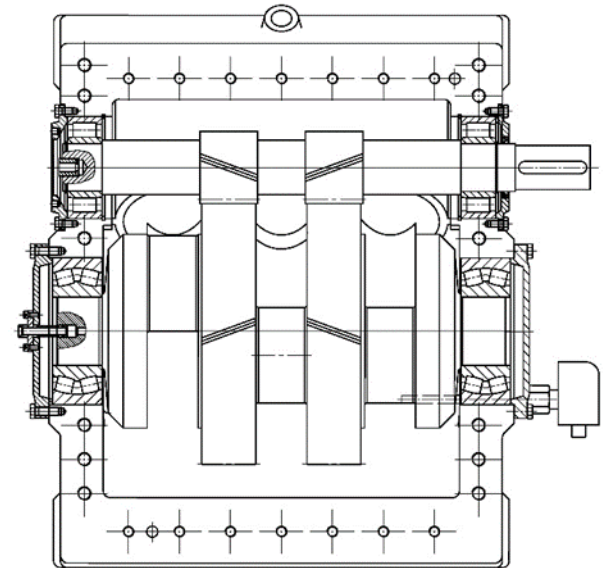

GEAR BOX



PUMP HEAD

- KAMAT plunger sealing sets work from 0 - max. bar and may even run dry
- pump head service without removing pump head

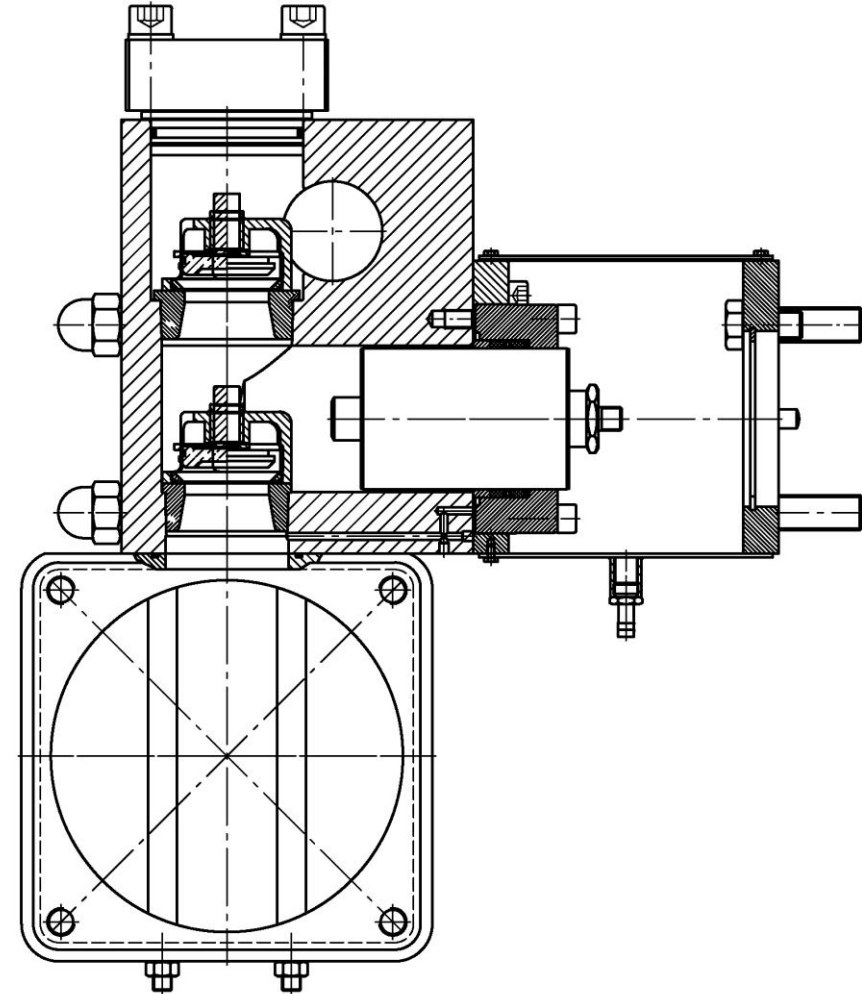

MC - VALVE

- with only two wearing parts to be replaced
- thus quick and cheap service
- abrasive resistant soft seal

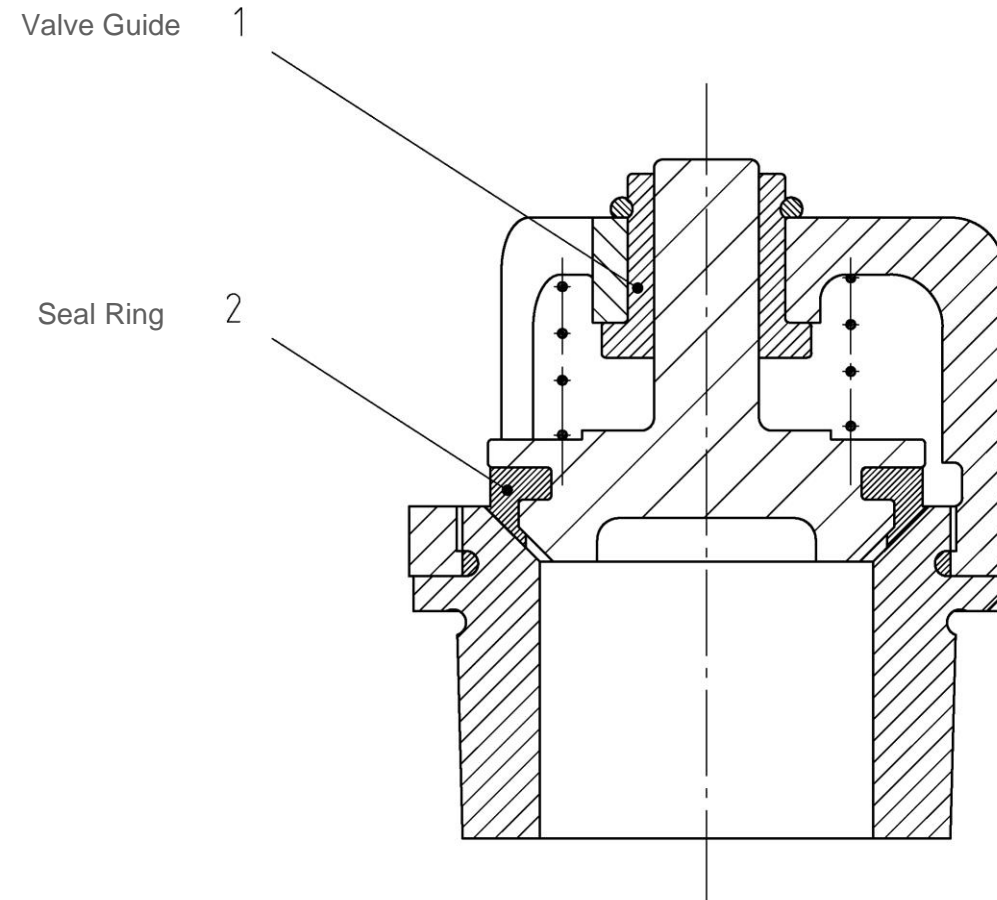

MC - VALVE

Change takes only a few minutes





KAMAT GmbH & Co. KG

Salinger Feld 10
D-58454 Witten

Tel: +49-2302-8903-0
Fax: +49-2302-801917

E-Mail: info@KAMAT.de
Web: www.KAMAT.de/en