



SINGLE VOLUTE TWIN SCREW PUMP SLM DSP-2C

SEALLESS WITH MAGNET DRIVE, ACC. TO API 676

Klaus Union GmbH & Co. KG

Experience – Responsibility – Passion

Pump series SLM DSP-2C acc. API 676

Utilizing the well known maintenance free Klaus Union magnetic drive system, the SLM DSP-2C provides a robust and trouble free solution for the customers' needs.

The Klaus Union pump series SLM DSP-2C is a single volute twin screw pump, engineered acc. to API 676, latest edition. It uses the same field proven, robust and highly flexible Klaus Union modular system of magnetic drives as the Klaus Union centrifugal pumps. This allows for full spare parts interchangeability between the magnetic drive systems for Klaus Union Centrifugal Pumps and Twin Screw Pumps.

The axial split modular casing design allows the pump to be adapted to the customers' needs without limiting spare parts interchangeability between pumps. This keeps the spare parts and life cycle costs for the twin screw pumps to a minimum.

Of course the pumps also feature the famous "PLUG & PUMP" Cartridge Design to minimize service downtimes.

The construction without shaft seal but with magnet drive guarantees that the pump is leak free, in accordance with the TA-Luft specification (German Technical Instruction on Air Quality Control), and maintenance-free in operation, compared to the version with mechanical seal.

The leak-free pumps are particularly suitable for pumping toxic, aggressive, flammable and other environmentally hazardous liquids in:

- ▶ Refineries
- ▶ On-/Offshore plants
- ▶ Petrochemical Industry
- ▶ Chemical Industry

The Klaus Union pump series SLM DSP-2C can be supplied with its own bearing bracket with grease or oil lubricated bearings, or in close coupled design. In case of grease lubricated bearings lifetime greased bearings are the standard, however regreaseable executions are available on request.

The optional available pressure limiting valve (PLV), using Klaus Union valve product line proven design and internals, can protect the pump hydraulic against overpressure and is executed with return to suction as a standard. If requested, the pump casing can be equipped with a connection to directly mount a standard API 520/526 grade safety valve.



Quality Assurance

A major component of the Klaus Union ethos is to ensure highest product quality. Existing quality assurance procedures with Klaus Union suppliers are constantly monitored from order placement to goods receipt and final assembly. This quality assurance system, developed on latest technologies, complies with the requirements of international regulations. Klaus Union is a DIN EN ISO 9001 certified company.

Performance Range

Flow Rate: Q = up to 600 m³/h
 Diff. Pressure: ΔP = up to 16 bar
 Higher flow rates upon request

Pressure Ratings

Standard construction: PN 25 at 120 °C
 Temperature Range: -120 °C up to 350 °C
 Pressure Rating: up to PN 25
 Higher pressure ratings upon request

Construction Materials

Pump Casing	Cast Carbon Steel; Cast Stainless Steel; Duplex Stainless Steel; Super Duplex Stainless Steel
Liner	Cast Carbon Steel; Cast Stainless Steel; Duplex Stainless Steel; Super Duplex Stainless Steel; Wear Resistant Coating
Screws	Carbon Steel, nitrated; Stainless Steel, hardened; Duplex Stainless Steel, hardened; Wear Resistant Coating; Martensitic Stainless Steel, nitrated
Containment Shell	Hastelloy C, Titanium, Alloy 718, Zirconium Oxide

Upon request, Klaus Union Screw Pumps, Series SLM DSP-2C, can be supplied also in Hastelloy, Inconel, other High Nickel Alloys or Titanium.



In accordance with TÜV NORD CERT procedures,

KLAUS UNION GmbH & Co. KG
 Blumenfeldstraße 18
 44795 Bochum
 and
 KLAUS UNION Service GmbH & Co. KG
 Blumenfeldstraße 18
 44795 Bochum

are certified according to DIN EN ISO 9001

Design Details SLM DSP-2C

Pump Screws

located side by side (horizontally), machined from a single piece bar stock, low pulsating design with optimized screw profile for minimized power consumption.

Adaptable Suction/Discharge Casing

to fit project requirements for nominal diameter, rating and execution. Engineered for smooth flow.

Flat Gasket

Compliant with technical instructions on air quality control (TA-Luft).

Radial Slide Bearings

optimized to meet customer application needs for maximum overall pump lifetime.

Large Diameter Balancing Lines

to prevent clogging due to solids or polymerizing fluids.

Intermediate Lantern
with magnet drive rub ring and assembly / disassembly guidance.

Magnetic Coupling
Parts interchangeable with centrifugal pump magnetic couplings. Available in API 685 compliant design on request.

Bearing Carrier
with high performance bearings following API 676 3rd Edition recommendations. Bearings available oil or grease lubricated (lifetime greased or regreaseable).

Single Containment Shell
with leakage monitoring and drain (secondary control/system) on request.
Optional: Double containment shell with pressure monitoring (secondary containment system).

Inner Magnet Carrier
with additional mechanical rub ring.

Centerline Mounting
as a standard. High shaft stability, even during change of operating temperature. Feet adaptable to customer requirements. Close coupled design possible with same casing.

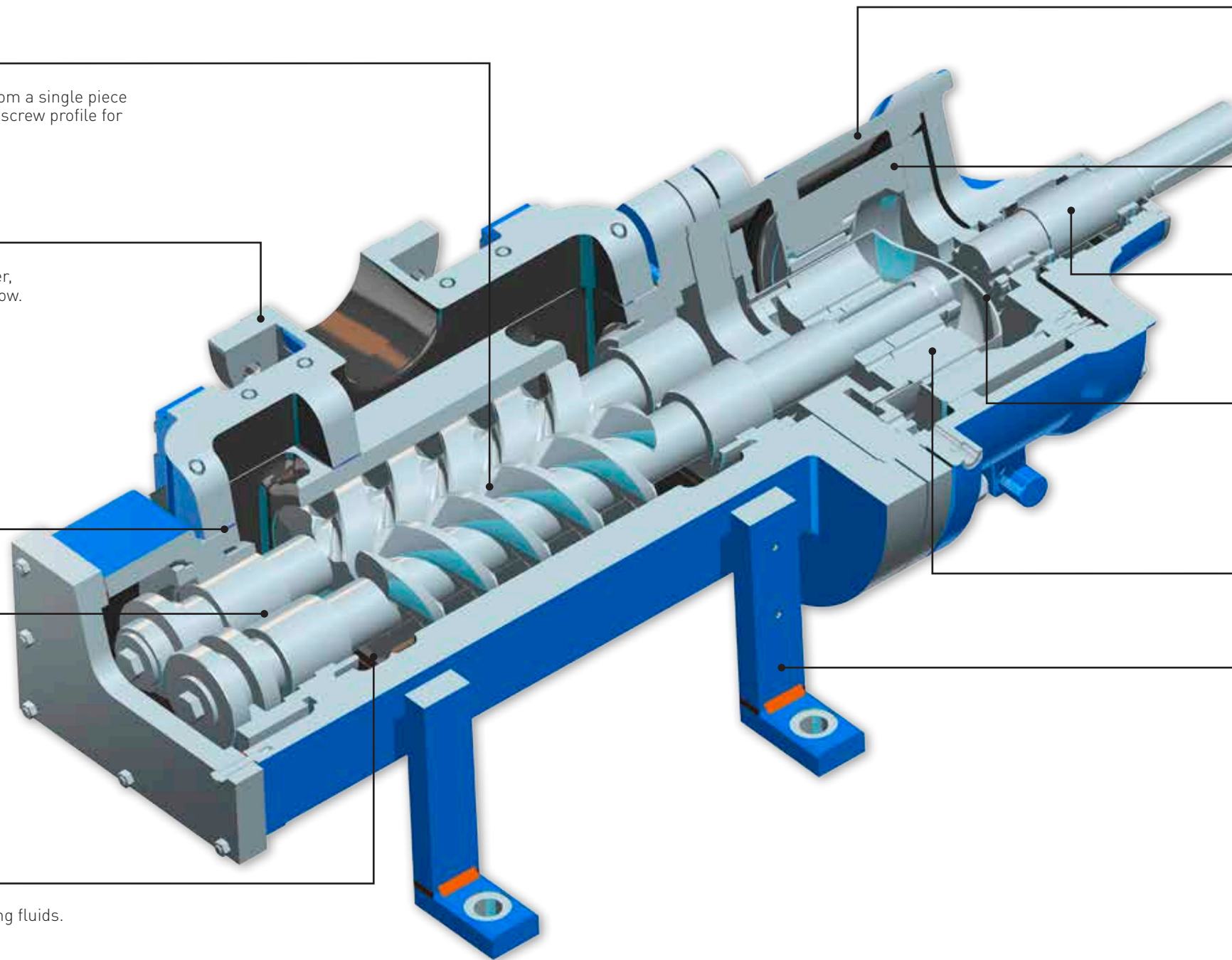



SLM DSP-2C – The Modular System for Sealless Twin Screw Pumps

Pump Casing

The design of pump casing has been calculated with the help of the finite element method (FEM) for 25 bar maximum internal pressure at 120 °C (for stainless steel) and a nozzle load corresponding to twice the values specified in API 676, 3rd Edition. The corrosion allowance of 3 mm stipulated acc. to API 676 has been taken into consideration as well.

The pumps are available with flanges acc. DIN EN 1092-1, PN 16 or PN 25 as well as ANSI/ASME B16.5 Class 150 and Class 300. Higher pressure ratings can be realized on request.

Centerline Mounting

The pump casing is equipped with centerline mounting as a standard. While this is common for centrifugal pumps most screw pumps today still come with a traditional foot mounted arrangement. The centerline mounting gives the customer several benefits:

- ▶ Minimum shaft dislocation during temperature cycles of the process
- ▶ Ease of maintenance - the pump hydraulic cartridge can be disassembled without disturbing motor or piping
- ▶ Good accessibility for heat tracing and/or temperature insulation
- ▶ Upgrading of existing SLM DSP-2C with modules to provide additional features (heating, external balancing lines, etc.) without impact on the core hydraulic unit
- ▶ High flexibility to accommodate customer requirements for interface dimensions by raising or lowering the pump.

Hydraulically Balanced Design

Large diameter balancing lines ensure the hydraulic balancing of the pump during all operating conditions. For crystallizing products the balancing lines can be supported by additional external balancing lines to avoid clogging and consequential damage to the pump and magnetic coupling. Ports for verifying proper operation of the balancing systems by means of suitable instruments are available on request.

Slide Bearings

Radial slide bearings, utilizing proven designs and experiences gained in our heavy duty, high load centrifugal pump slide bearings, carry the rotors inside the pumped fluid and are lubricated by the pumped fluid.

Close Coupled Design

The SLM DSP-2C is also available in a close coupled version (SLM DSP-2CB). The Closed Coupled Design offers significant cost savings because of the following advantages:

- ▶ No alignment between pump and motor required
- ▶ No coupling and coupling guard
- ▶ No ball bearings
- ▶ Pump completely free of scheduled maintenance
- ▶ No oil lubrication necessary
- ▶ Lower noise level
- ▶ Base plates for close coupled design do not need to be rigid acc. to API 685 - 7.3

Magnet Drive as per API 685 - 9.1.3./6.1.9

The magnet drive is configured concentrically and transmits torque without slip via the field of the permanent magnets. The thermally stable samarium-cobalt material (Sm2Co17) withstands operating temperatures of up to 400 °C.

A pressurised flush flow is taken off at a high pressure location in the hydraulic system and fed to the magnet drive, where it provides for the necessary heat dissipation. The pressurised flush flow ensures that the temperature rise in the containment shell area does not lead to evaporation of the pumped liquid (see Fig. 2).

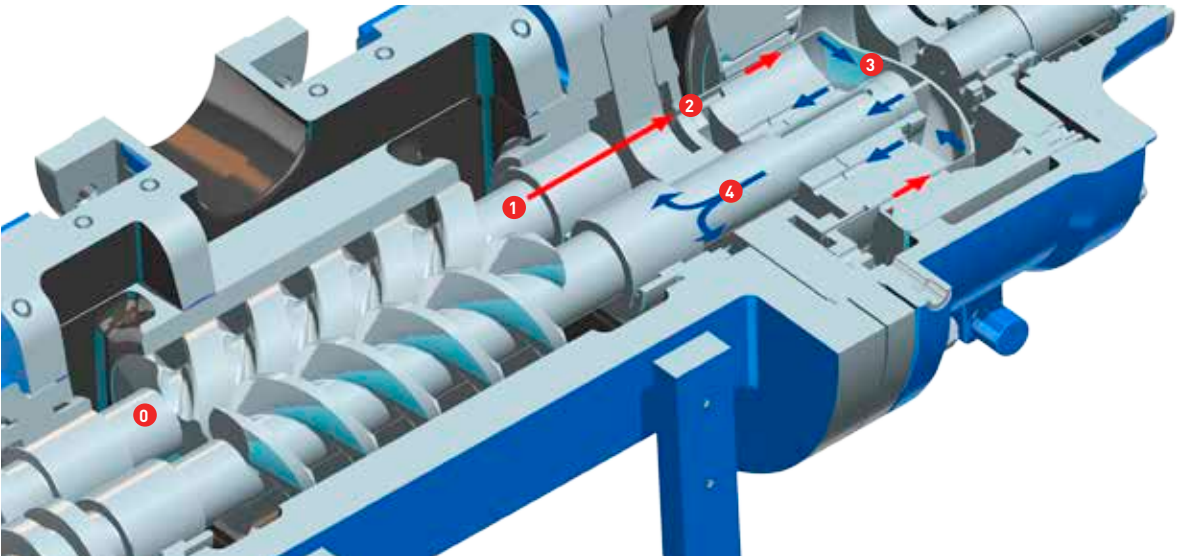
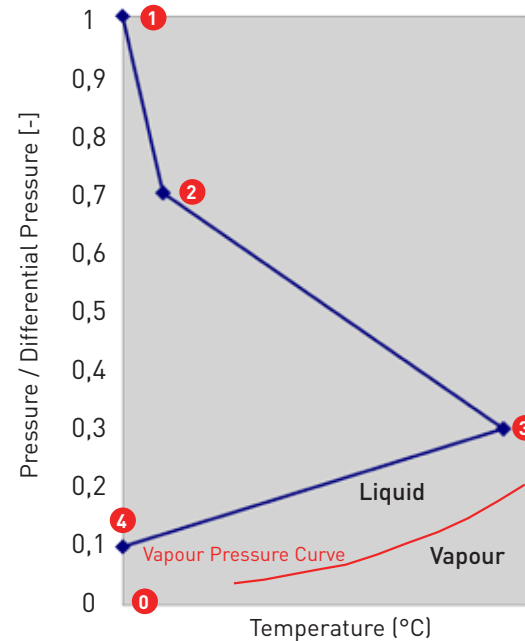

Klaus Union Standards & Optional Packages acc. to API 685 2nd Ed.

Single Containment Shell with Drain at the Intermediate Lantern (Fig. 3.)

The standard version of the SLM DSP-2C pump is equipped with a single containment shell. The intermediate lantern is equipped with a labyrinth system to the atmosphere and a drain connection (D1). A pressure gauge or a liquid sensor can be utilized as a leakage monitor. The labyrinth seal upstream of the anti-friction bearings serves as a throttling point in the event of containment shell damage leading to product escaping into the intermediate lantern. The pressure rise or the presence of liquid is detected by the monitoring system.

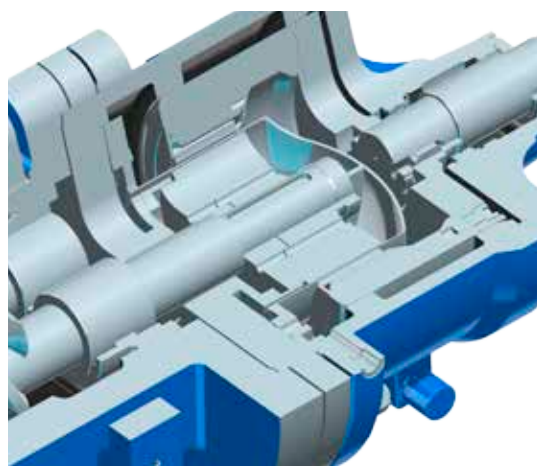

Optional Packages

- ▶ Special / customized baseplates
- ▶ Various heating options adapted to customer and application requirements
- ▶ Flushing connections
- ▶ High Pressure Design for increased inlet pressure systems (up to 400 bar)
- ▶ Instruments to verify proper operation of pump and early failure detection
- ▶ Mag Drive Systems optimized for highest viscosities
- ▶ High Efficiency magnetic coupling systems optimized to customer operating needs

Secondary Containment System as per API 685 - 3.66 (PE + TE3)

- ▶ Double containment shell
- ▶ Monitoring device on containment shell manifold, pressure sensor (PE)
- ▶ Flushing of contaminated isolation shell after breach of the inner shell can be accomplished by introducing flush liquid into the manifold. The flush liquid will decontaminate the cavity between both shells and exit thru the breached inner shell into the process area
- ▶ Drain hole in intermediate lantern plugged (welded or threaded)
- ▶ TPX Temperature monitoring system (TE3)
- ▶ Alternatives available on request

Secondary Control as per API 685 - 3.67 (JE + LE1 + D2)

- ▶ Single containment shell
- ▶ Pump power monitoring (JE)
- ▶ Liquid detection in vertical section of the discharge piping system (LE1)
- ▶ Secondary, welded drain connection on intermediate lantern with flange/ blinded backup bearing seal on drive shaft (D2)

Secondary Control System as per API 685 - 3.68 with Liquid Sensor (LE2)

- ▶ Welded drain connection on intermediate lantern with flange/blinded
- ▶ 3-way adapter on drain connection
- ▶ Backup seal on drive shaft
- ▶ Monitoring device, liquid detector (LE2)

Secondary Control System as per API 685 - 3.68 with Pressure Sensor (PE)

- ▶ Welded drain connection on intermediate lantern with flange/blinded
- ▶ 3-way adapter on drain connection
- ▶ Backup seal on drive shaft
- ▶ Monitoring device, pressure transmitter (PE)

Basic Monitoring (TE3 + JE)

- ▶ TPX Temperature monitoring system (TE3)
- ▶ Load controller (JE)





Performance Curves SLM DSP-2C

Performance Curve 50 Hz

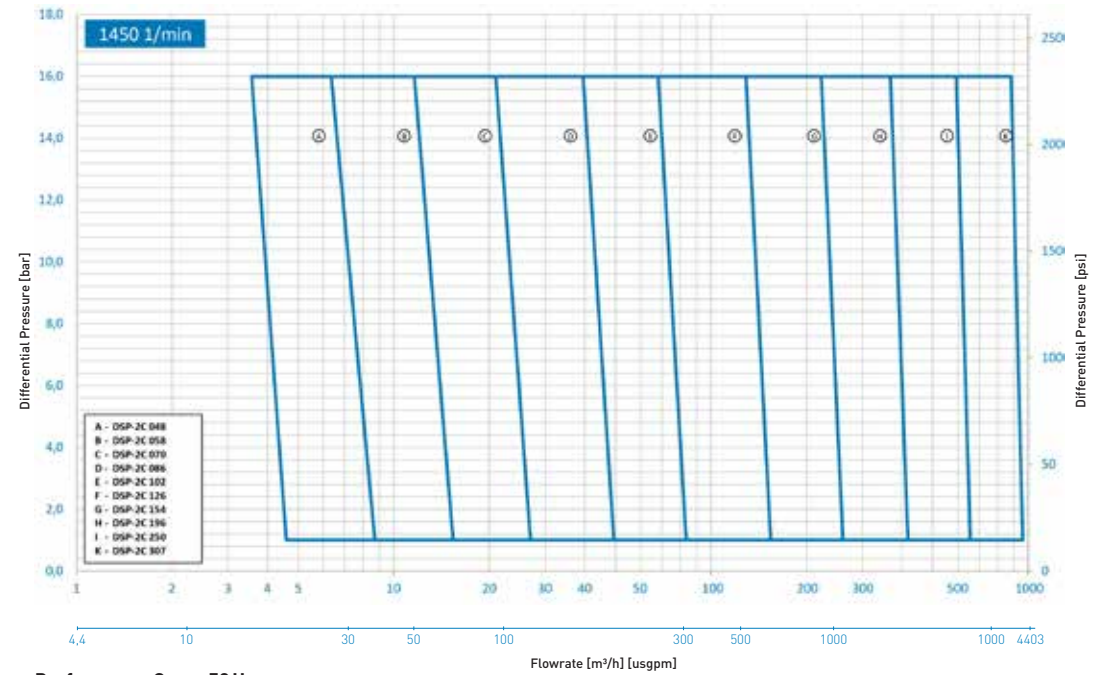

Performance Curve 60 Hz

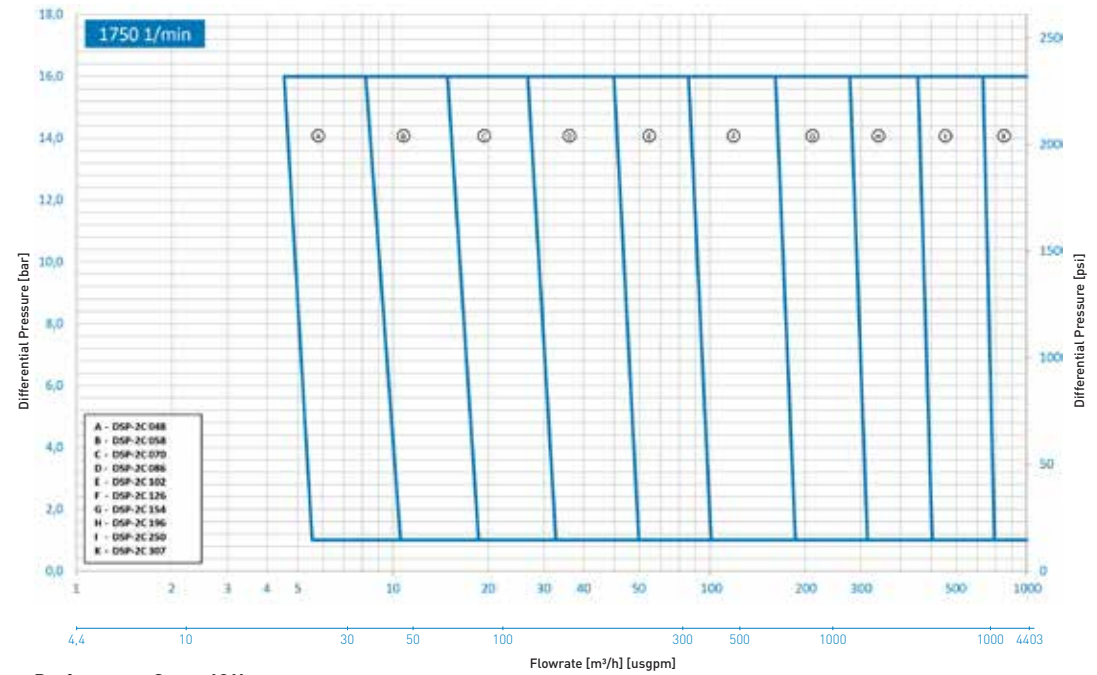

Performance Curve 50 Hz

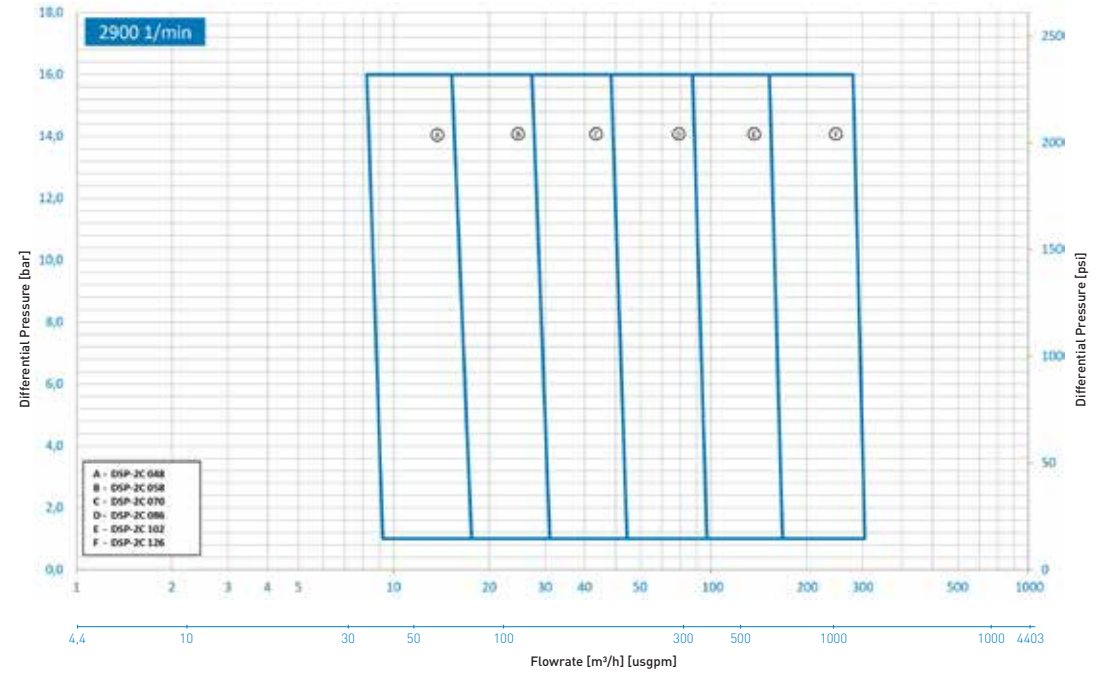

Performance Curve 60 Hz

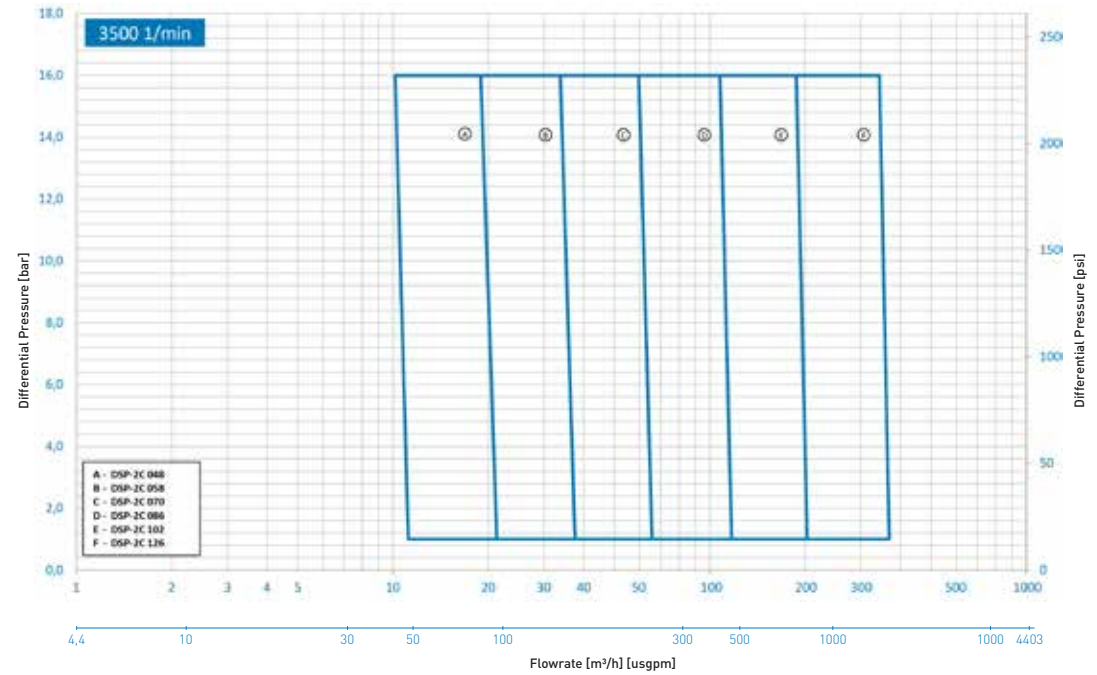

Product Range Pumps:

Pumps with Magnet Drive

- E Centrifugal Pumps acc. to DIN EN ISO 2858 & DIN EN ISO 15783, SLM NV
- E Centrifugal Pumps acc. to ANSI B73.3, SLM AVO
- E Centrifugal Pumps for Petrochemical Applications acc. to API 685, SLM AVP / SLM APC
- E Centrifugal Pumps for High Pressure Applications, SLM SV / SLM GV
- E Centrifugal Pumps for High Temperature Applications, SLM NHO
- E Centrifugal Pumps for Liquids Containing Solids, SLM NV OT
- E Self-Priming Centrifugal Pumps, SLM SV
- E Multistage Centrifugal Pumps, Tension-Rod or Barrel-Type Design, SLM GV
- E Submerged Centrifugal Pumps, SLM NVT
- E Double-Suction Centrifugal Pumps, SLM ZV
- E Twin Screw Pumps acc. API 676, SLM DSP-2C

Pumps with Shaft Sealing

- E Centrifugal Pumps acc. to DIN EN ISO 2858 & DIN EN ISO 5199, NOV
- E Multistage Centrifugal Pumps, Tension-Rod or Barrel-Type Design, GOV / GOVT
- E Horizontal and Vertical Propeller Pumps, P
- E Bottom-Flange Propeller Pumps, UP
- E Submerged Centrifugal Pumps, TP NO
- E Double Suction Centrifugal Pumps, NZ
- E Twin Screw Pumps acc. API 676, DSP-2C / DSP-4C

Product Range Valves:

- E Globe Valves, T
- E Globe Valves, Y
- E Gate Valves, Isomorphous Construction Series
- E Gate Valves, Wedge or Wedge Plates
- E Relief Valves
- E Check Valves
- E Sight Glasses
- E Strainers
- E Filters
- E Bottom Valves
- E Safety Valves

Klaus Union Service Performance:

- E Workshop / On-Site Repairs
- E Genuine Spare Part Delivery Worldwide
- E Spare Parts Storage
- E Customized Spare Parts Management
- E On-Site Maintenance
- E Installation
- E Retrofitting
- E On-Site Testing / Monitoring
- E Customer Advisory Service
- E Start Up & Commissioning
- E Individual 24 / 7-Service
- E Trouble-Shooting
- E In-House & On-Site Training
- E On-Site Assembly and Disassembly
- E Long-Term Maintenance Contracts
- E Maintenance Planning and Consulting
- E Diagnostics

Klaus Union, Inc.

15410 Lillja Rd.
Houston, TX 77060

Phone 281-999-1182
Fax 281-999-1185
Email info@klausunion.com
Internet www.klausunion.com

