



TSINGSHAN



STAINLESS STEEL SEAMLESS PIPES & TUBES / 不锈钢无缝钢管

SS WELDED PIPES / 不锈钢焊接钢管

SS FITTINGS / 不锈钢管件

SS BRIGHT ANNEALING TUBES / 不锈钢光亮管

SS BRIGHT BARS / 不锈钢光亮棒

**浙江青山钢管有限公司**  
ZHEJIANG TSINGSHAN STEEL PIPE CO., LTD.



浙江青山钢管有限公司成立于2003年，隶属于青山实业旗下信拓集团，注册资金3.2亿元，占地面积约8.5万平方米，是一家集不锈钢无缝钢管、焊管、管件、光亮管和光亮棒于一体的生产经营型企业。不锈钢无缝钢管、焊管、管件、光亮管和光亮棒的年产能分别为35000吨、20000吨、3000吨、1000吨和3000吨，广泛应用于石油、化工、炼油、化学、机械、电力、造船、造纸、制药、食品等领域。

公司拥有ISO9001、ISO14001、OHSAS18001、ISO17025、API5LC、PED+AD2000、Norsok M650、ASME、CCS、ABS、BV、DNV·GL、LR、RINA和KR等证书，并获得中石油、中石化、中海油、ExxonMobil、BP、Petrobras、KOC、Petronas、GS、Thaioil、Keppel、Reliance、Sabic和ADNOC等知名终端客户以及Saipem、Technip、TR、Petrofac、KBR、EIL、L&T、Chiyoda、Hyundai、Samsung、Doosan和Daewoo等工程公司的资质认可。

公司始终坚持千锤百炼、追求卓越的青山精神，为客户提供优质的产品和服务！

Zhejiang Tsingshan Steel Pipe Co., Ltd., a subordinate to Sinotube Group Co., Ltd. attached to Tsingshan Holding Group, was founded in 2003 with 320 million Chinese Yuan registered capital. It is an integrated and experienced manufacturer to provide one-stop engineering support services with the package supply of stainless steel seamless • welded pipes • tubes • fittings • bright annealing tubes • bright bars and the annual production capacity is 35000 tons, 20000 tons, 3000 tons, 1000 tons and 3000 tons respectively. Tsingshan products are widely applied to various industries including petroleum, petrochemical, refinery, chemical, machinery, power, shipbuilding, paper-making, pharmacy and food, etc. Tsingshan have ISO9001, ISO14001, OHSAS18001, ISO17025, API 5LC, PED+AD2000, Norsok M650, ASME, CCS, ABS, BV, DNV·GL, LR, RINA and KR certificates and get approval from celebrated end users and EPC companies such as PetroChina, Sinopec, CNOOC, ExxonMobil, BP, Petrobras, KOC, Petronas, GS, Thaioil, Keppel, Reliance, Sabic, ADNOC and Saipem, Technip, TR, Petrofac, KBR, EIL, L&T, Chiyoda, Hyundai, Samsung, Doosan and Daewoo, etc. Tsingshan is committed to providing high-quality products and professional service with the spirit of fighting and struggling for excellence.



## 产品介绍

### MAJOR PRODUCTS

#### 产品尺寸 / PRODUCT SIZE

产品 Products	外径 OD	壁厚 WT	长度 Length
不锈钢无缝钢管 Stainless Steel Seamless Pipe & Tube	6-813mm	0.5-50mm	Max 24m
U型管 U-Bent Tubes	6-32mm	0.5-3.5mm	Max 26m

#### 产品和牌号 / PRODUCT AND GRADES

钢种 Types	牌号 Grades
奥氏体不锈钢 Austenitic Stainless Steel	TP304, TP304L, TP304LN, TP304H, S30432, TP310S, TP310H, TP310HCBN, S31050, TP316, TP316L, TP316LN, TP316TI, TP316LMOD, TP317L, TP321, TP321H, TP347, TP347H, TP347HFG
超级奥氏体不锈钢 Super Austenitic Stainless Steel	N08904, N08367, S31254
铁素体/奥氏体双相不锈钢 Ferrite-Austenitic Duplex Stainless Steel	S31500, S31803, S32205, S32750, S32760
镍基合金 Ni-Alloy	N08800, N08810, N08811, N08020, N08825, N08028, N06600, N06601, N06625
API耐蚀合金 API Corrosion Resistant Alloy	LC30-1812, LC65-2205, LC65-2506, LC80-2507, LC30-2242



产品标准 / PRODUCT STANDARDS

<b>标准类型</b> <b>Standard Types</b>	<b>生产标准</b> <b>Standard</b>
<b>ASTM</b>	ASTM A312 , ASTM A213 , ASTM A269 , ASTM A376 , ASTM A511 , ASTM A789 , ASTM A790 , ASTM B163 , ASTM B167 , ASTM B407 , ASTM B423 , ASTM B444 , ASTM B677
<b>ASME</b>	ASME SA312 , ASME SA789 , ASME SA790 , ASME SA376 , ASME SA213 , ASME SB163 , ASME SB167 , ASME SB407 , ASME SB423 , ASME SB444 , ASME SB677
<b>API</b>	API 5LC
<b>JIS</b>	JIS G3459 , JIS G3463
<b>EN</b>	EN 10216-5 , EN 10216-2
<b>GOST</b>	GOST 5632-72 , GOST 9941-81
<b>GB</b>	GB/T 14975 , GB/T 14976 , GB 13296 , GB 5310 , GB 9948 , GB/T 21833
<b>DIN</b>	DIN 17456 , DIN 17458
<b>船规</b> <b>Industrial</b> <b>Certificates</b>	ABS , CCS , DNV•GL , LR , RINA , BV , KR



# 生产工艺流程

## MANUFACTURING PROCESS

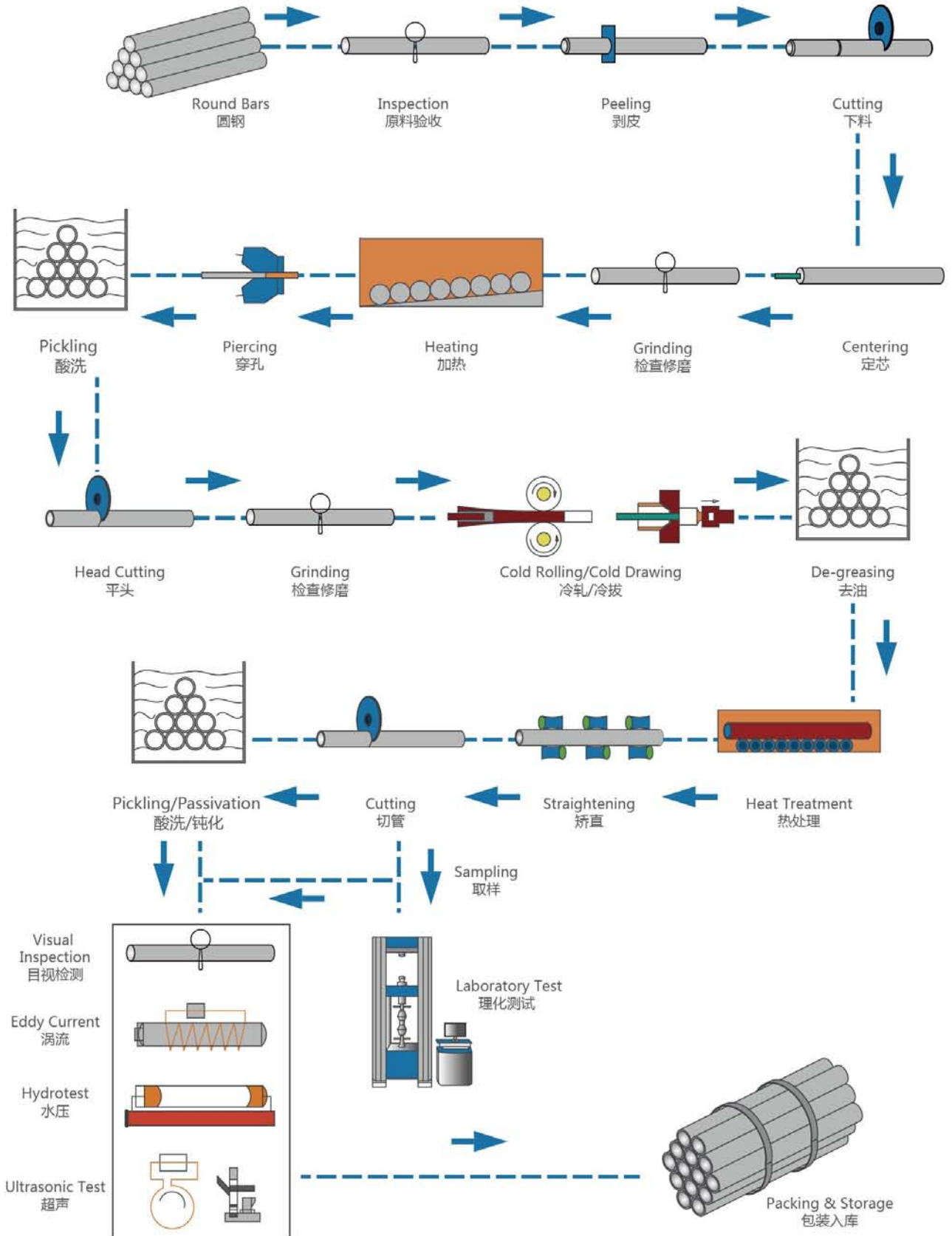

# 不锈钢焊接钢管 / SS WELDED PIPES

## 主要生产能力

## PRODUCTION CAPACITY

产品名称 Product Name	执行标准 Standard	外径范围 ( mm ) Outer Diameter	壁厚范围 ( mm ) Wall Thickness	长度范围 ( mm ) Length	年产量(T) Annual Output
工业配管用 不锈钢焊管 SS Welded Pipes & Tubes for Industrial Use	ASTM : A312、 A358、A790、 A928、A268、 A269 API : API Spec5LC EN : EN 10217-7 JIS:G3459、G3468 GB : GB/T 12771、 GB/T 21832 HG:HG 20537.1~4	连续成型焊管 Continuously welded pipes & tubes 3/8" ~ 16"(17.15 ~ 406.4)  单支成型直缝焊管 Longitudinally welded pipes after bending 10" ~ 56"(273.05 ~ 1422)  单支成型环缝焊管， 最大外径80" ( 2032 ) Circumferentially welded pipes after bending; maximum OD 80" ( 2032 )	连续成型焊管5S ~ 40S ( 1.24 ~ 9.53 ) Continuously welded pipes & tubes  单支成型焊管 Welded pipes after bending 5S ~ XXS ( 3 ~ 40 )	连续成型焊管 3000 ~ 12000 Continuously welded pipes & tubes  单支成型焊管 Welded pipes after bending 1000 ~ 12000	15000
机械结构用不锈 钢焊管 SS Welded Pipes & Tubes for Mechanical Use	ASTM A554 GB/T 12770 JIS G3446 EN 10217-7	12 ~ 325	0.5 ~ 10	3000 ~ 12000	5000
锅炉热交换器、 冷凝器用不锈 钢焊管 SS Welded Pipes & Tubes for Boiler Heat Exchanger and Condenser	ASTM A249 JIS G3463 DIN 17457 EN 10217-7 GB/T 24593	ASTM A249 19.1 ~ 101.6  其它标准 other standards (15.9 ~ 219.08)	ASTM A249 0.5 ~ 3  其它标准 other standards 0.5 ~ 6	3000 ~ 18000	3000
给水用不锈 钢焊管 SS Welded Pipes & Tubes for Water Supply	JIS G3448 EN 10312 GB/T 12771 GB/T 19228 CJ/T 151	10 ~ 406	0.6 ~ 6	3000 ~ 12000	3000

# 连续成型焊管生产工艺图

## CONTINUOUS MANUFACTURING PROCESS OF WELDED PIPES & TUBES

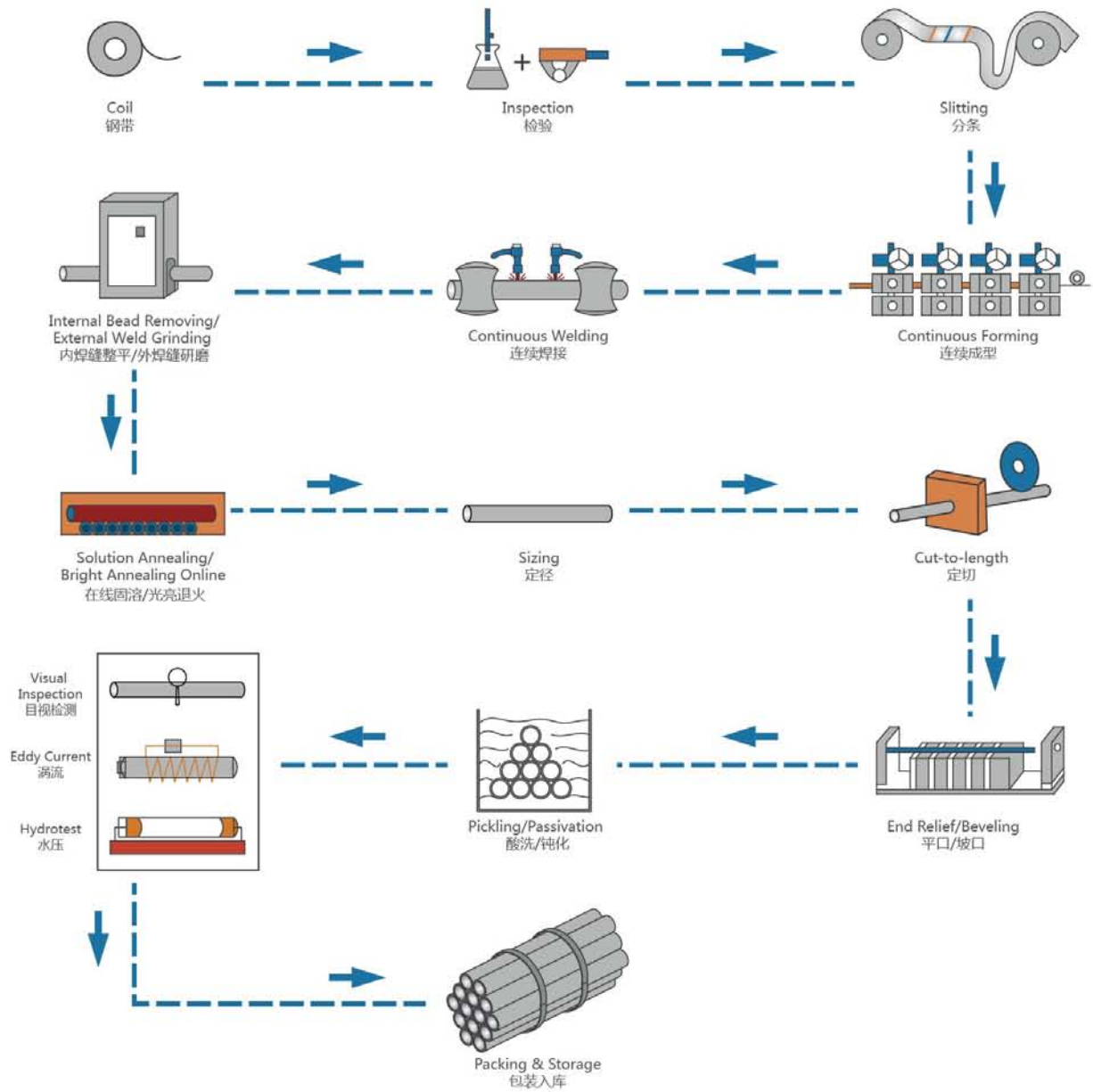

# 单支成型焊管生产工艺图

## BENDING PROCESS OF WELDED PIPES

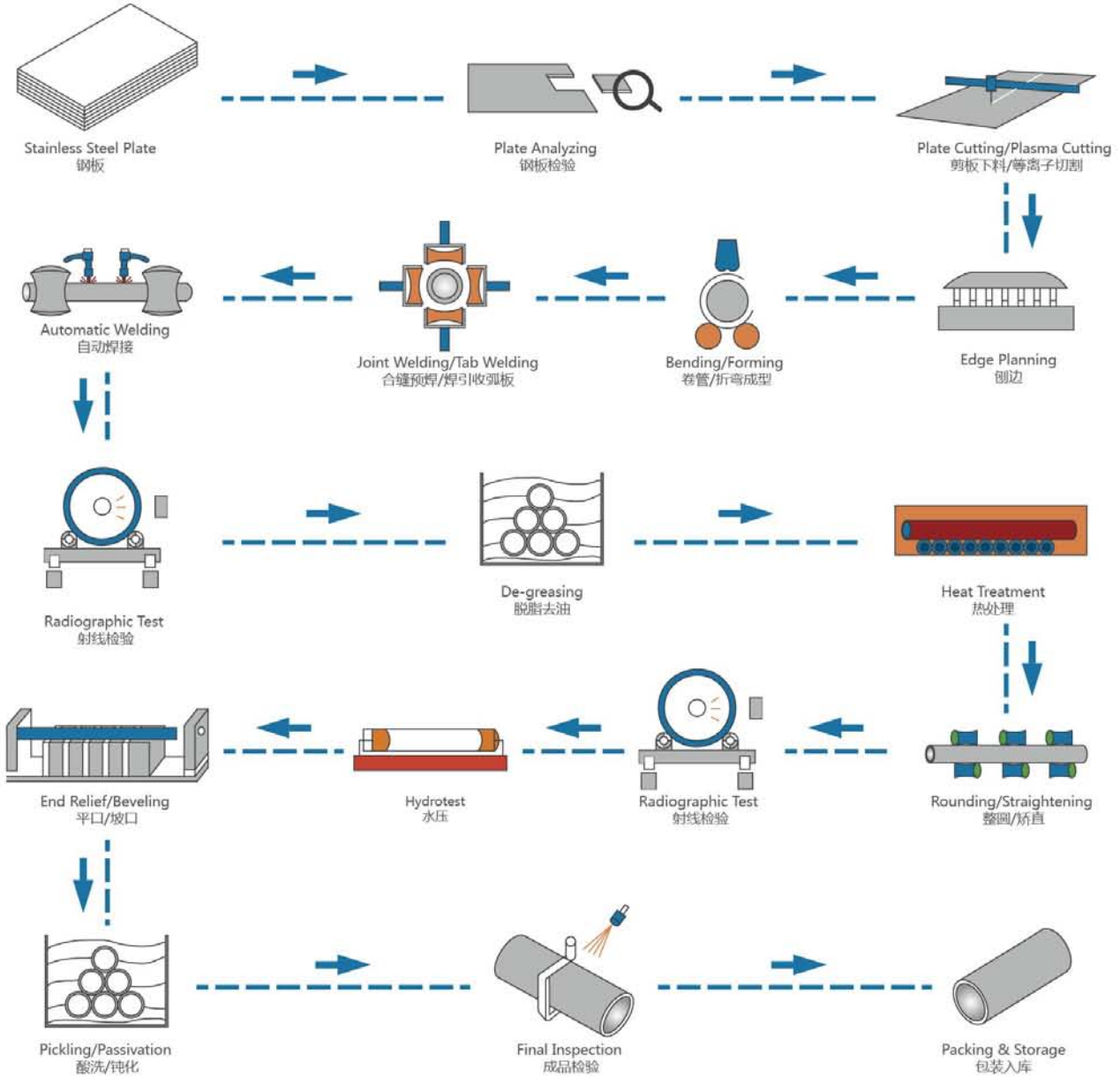



我们的产品

OUR PRODUCTS



CROSS  
四通



CAP  
管帽



45° LR ELBOW  
45度长径弯头



EQUAL TEE  
等径三通



90° LR ELBOW  
90度长径弯头



STUB END  
翻边



ECCENTRIC  
REDUCER  
偏心大小头



90° SR ELBOW  
90度短径弯头



REDUCING TEE  
异径三通



180° RETURN  
180度弯头



CONCENTRIC  
REDUCER  
同心大小头



生产范围 / PRODUCTION RANGE

尺寸/Size: Seamless Fittings from 1/2" to 14"

Welded Fittings from 1/2" to 40"

类型/Type: WP-S WP-W WP-WX

材质/Grade: WP304 WP304L WP310S WP316 WP316L  
WP321 WP321H WP347H S31803 S32205 1.4301 1.4307 1.4845  
1.4401 1.4404 1.4541 1.4571

标准/Specification: GB/T 12459, GB/T 13401, SH 3408, SH 3409,  
ASTM A403, ASTM A815, ASME SA403, ASME SA815,  
ASME B16.9, ASME B16.28, ASME B16.25, EN10253-4

常用牌号 / GENERAL GRADES

类型 Series	ASTM	UNS Designation	GB (2007版)	GB (1992版)	EN	JIS
奥氏体 不锈钢 Austenitic Stainless Steel	WP304	S30400	06Cr19Ni10	0Cr18Ni9	1.4301	SUS304
	WP304L	S30403	022Cr19Ni10	00Cr19Ni10	1.4307	SUS304L
	WP304H	S30409	-	-	-	SUS304H
	WP316	S31600	06Cr17Ni12Mo2	0Cr17Ni12Mo2	1.4401	SUS316
	WP316L	S31603	022Cr17Ni12Mo2	00Cr17Ni14Mo2	1.4404	SUS316L
	-	-	-	-	1.4571	SUS316Ti
	WP317L	S31703	022Cr19Ni13Mo3	00Cr19Ni13Mo3	-	SUS317L
	WP321	S32100	06Cr18Ni11Ti	0Cr18Ni10Ti	1.4541	SUS321
	WP321H	S32109	07Cr19Ni11Ti	-	-	SUS321H
	WP310S	S31008	06Cr25Ni20	0Cr25Ni20	1.4845	SUS310S
	WP347	S34700	06Cr18Ni11Nb	0Cr18Ni11Nb	-	SUS347
	WP347H	S34709	07Cr18Ni11Nb	-	-	SUS347H
	WP904L	N08904	-	-	1.4539	-
	WPS31254	S31254	-	-	-	-
双相钢 Duplex	WPS31803	S31803	-	0Cr26Ni5Mo2	1.4462	-
	WPS32205	S32205	-	-	1.4462	-
	WPS32750	S32750	-	-	-	-
	WPS32760	-	-	-	-	-

# 生产工艺流程

## MANUFACTURING PROCESS

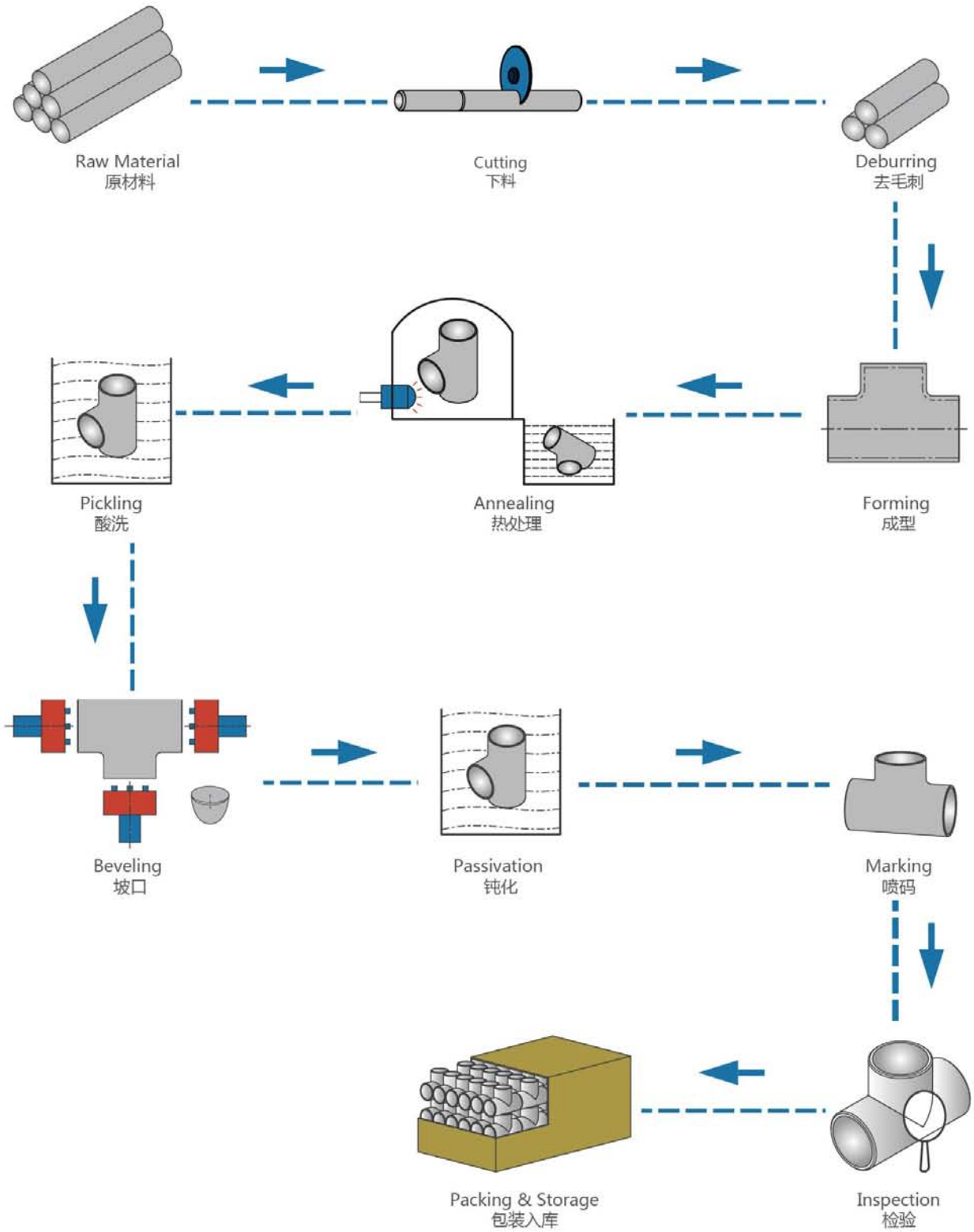

# 不锈钢光亮管 / SS BRIGHT ANNEALING TUBES

产品概况

PRODUCTS



## 光亮管 / BA TUBES

产品规格生产范围 Product range

外径 (OD) : 3.18-219.1mm

壁厚 (WT) : 0.2-8.18mm

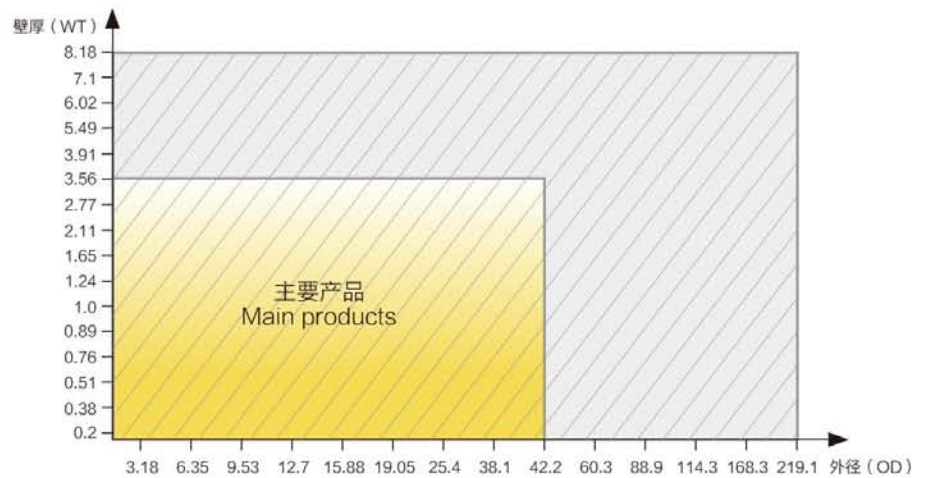

抛光管 / POLISHED TUBES

产品规格生产范围 Product range

外径 (OD) : 6-219.1mm

壁厚 (WT) : 0.51-12.7mm

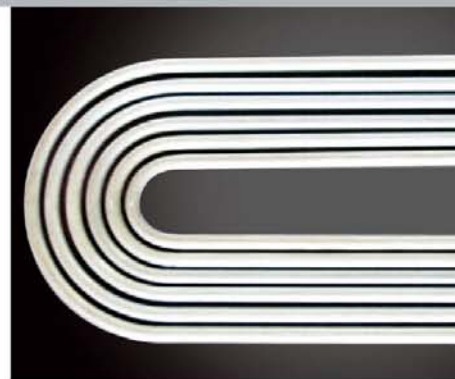
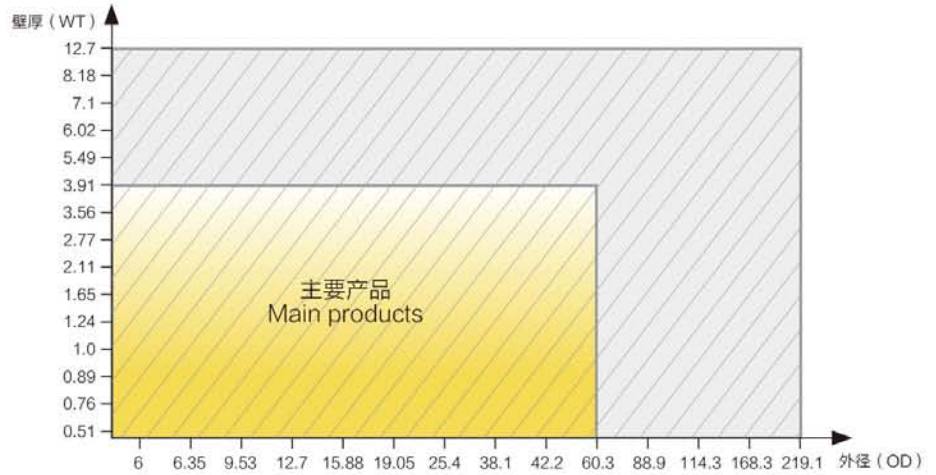

酸洗管 / AP TUBES

产品规格生产范围 Product range

外径 (OD) : 6-323.9mm

壁厚 (WT) : 0.51-25.4mm

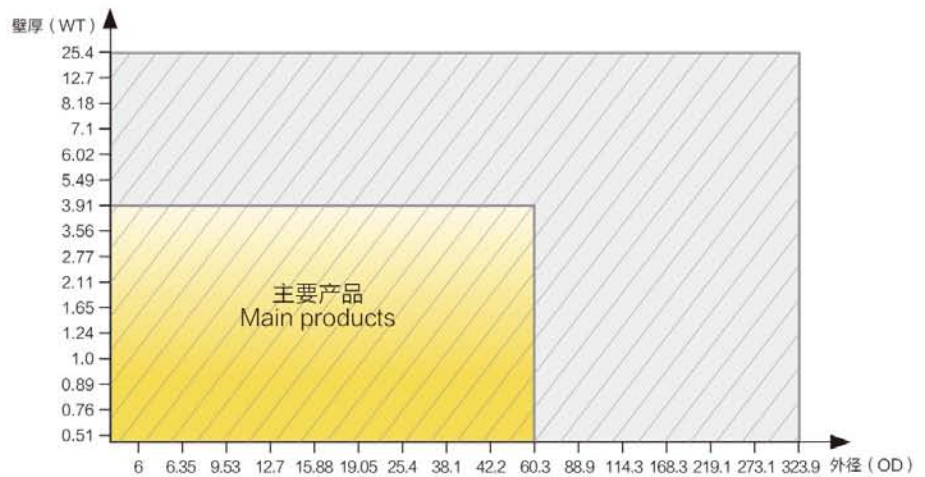

# 生产流程

## PRODUCTION PROCESS

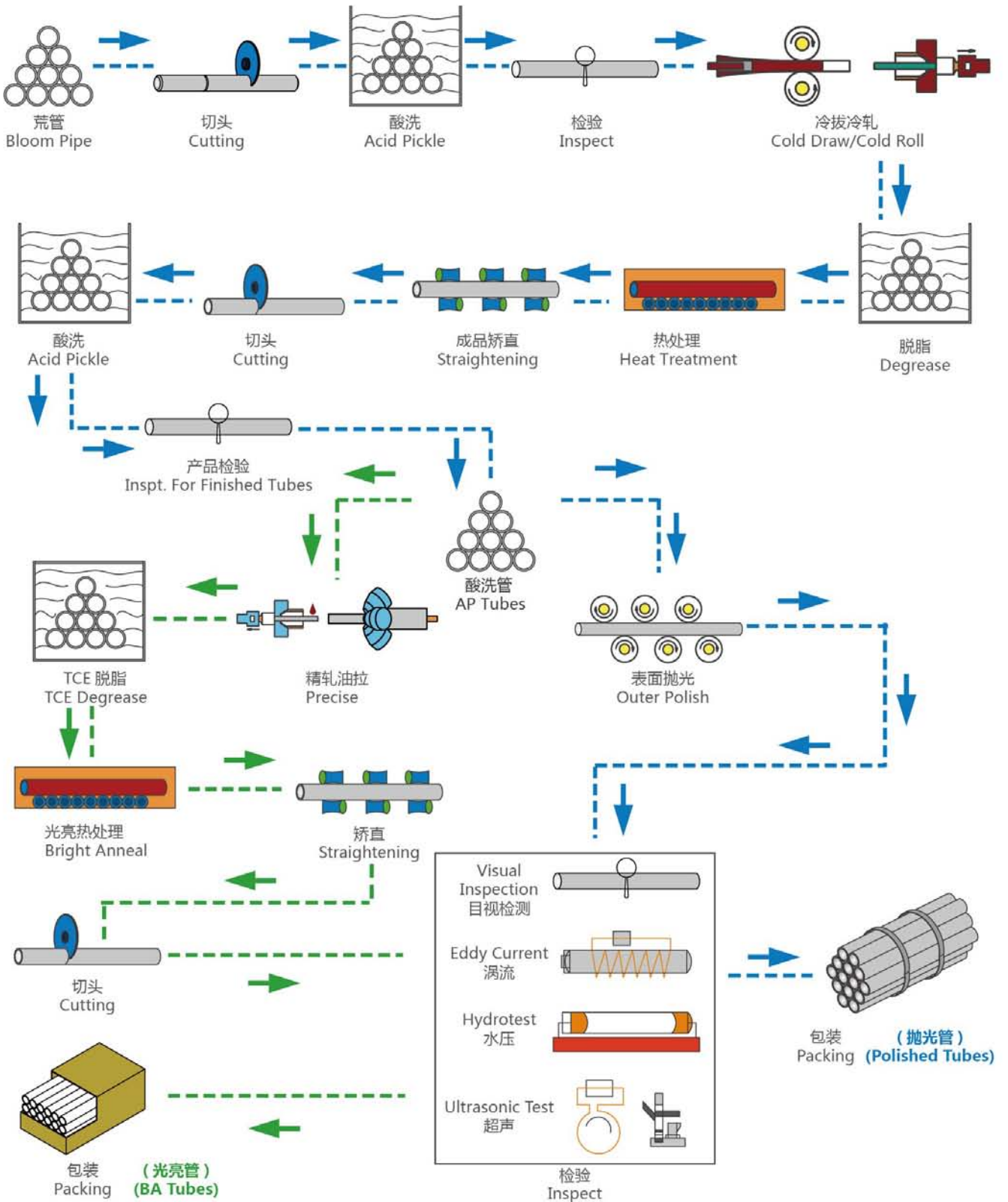

## 主营业务及标准

## MAIN PRODUCTS AND STANDARDS

产品名称 Main Products		主要钢种 Main Grades	尺寸范围 Available size (mm)	长度范围 Length (mm)	执行标准 Standard	备注说明 Remarks
热轧棒 Hot Rolling Bar		303, 303Cu, 304/L, 316/L, 310S, 321, 410, 420, 416, 17-4PH, 201Cu	15-180	4000-7500	GB, JIS, ASTM, EN, DIN	可依需要定制 As demand
剥皮棒 Peeling Bar		303, 303Cu, 304/L, 316/L, 310S, 321, 416, 17-4PH, 201Cu	15-100	3000-7500		
冷抽棒 CD Bar	圆棒 Round Bar	303, 303Cu, 304/L, 316/L, 321, 416, 17-4PH, 201Cu	2-100	2000-6000		
	四角棒 Square Bar	303, 303Cu, 304/L, 316/L, 321, 416, 17-4PH, 201Cu	5-50	2000-6000		
	六角棒 Hex Bar	303, 303Cu, 304/L, 316/L, 321, 416, 17-4PH, 201Cu	5-50	2000-6000		
无心研磨棒 CG Bar		303, 303Cu, 304/L, 316/L, 321, 416, 17-4PH, 201Cu	2-100	2000-6000		



# 生产流程

## PRODUCTION PROCESS

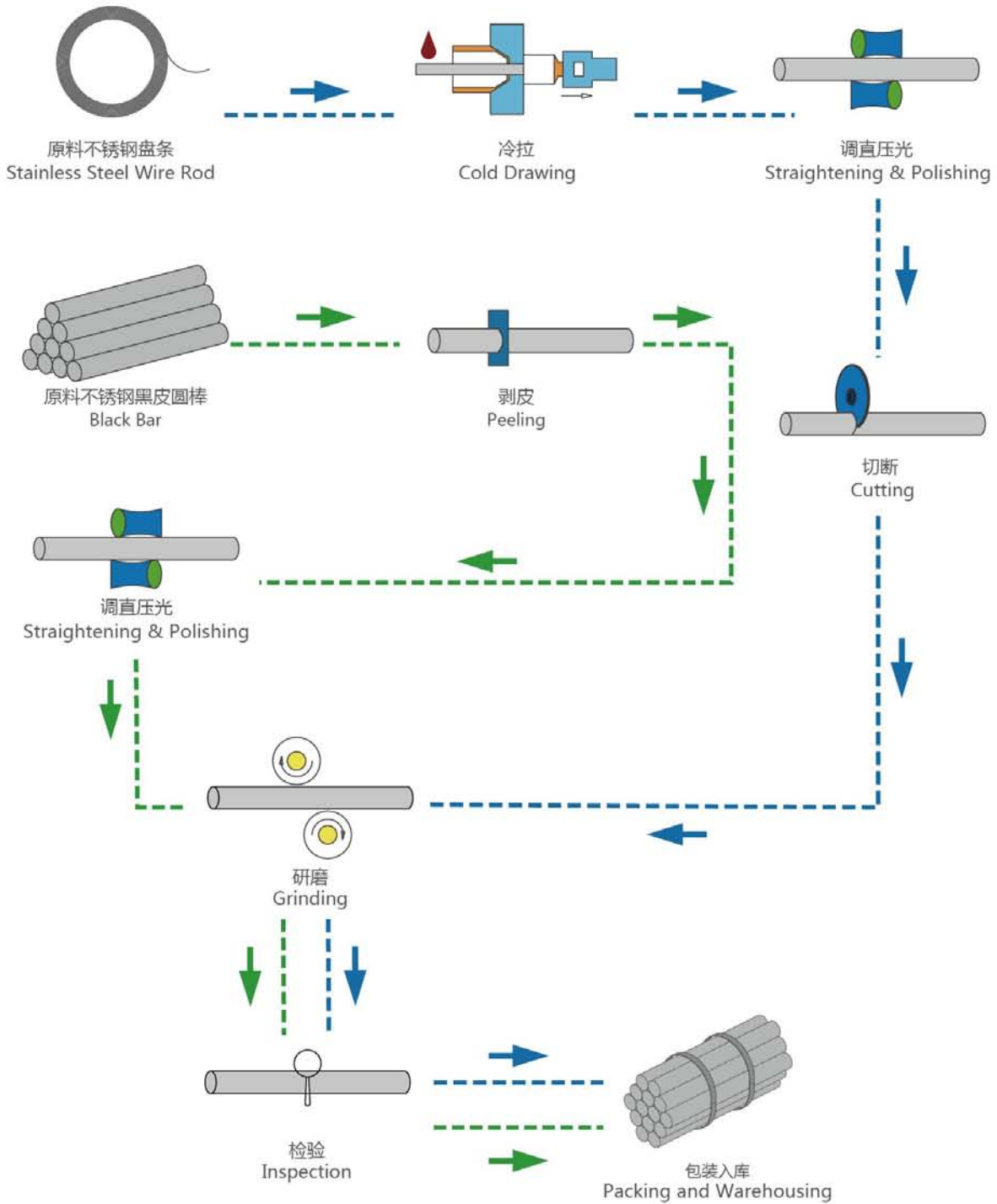



## 实验中心 / R&D CENTER

浙江青山钢管有限公司实验室始建于2008年，现面积已达1350m<sup>2</sup>。实验室已通过CNAS认证，具备国内、国际标准检测能力。青山一直坚持“规范管理、客观公正、精益求精、客户满意”的质量方针，把实验室建设成不锈钢管行业中权威的先进实验室。

The laboratory of Zhejiang Tsingshan Steel Pipe Co., Ltd. was established in 2008 and now with a total area of 1350m<sup>2</sup>, and it was CNAS approved with both Chinese and international standards. Tsingshan follows "standardized management, objective justice, continuous improving and customer satisfaction", and make the laboratory the leading one in the stainless steel industry.



## 资质认证 / QUALIFICATION CERTIFICATES



ISO9001证书 ISO14001证书 OSHA18001证书  
 ASME证书 PED+AD 2000证书 Norsok M650  
 CU-TR证书 GOST证书 CCS证书 ABS证书  
 BV证书 DNV-GL证书 RINA证书 LR证书  
 KR证书 特种设备（压力管道元件）制造许可证  
 实验室CNAS证书 API5LC证书

业绩 / MAJOR REFERENCE

国内

DOMESTIC



国外  
OVERSEAS





1. 温州总部大楼 / Wenzhou Headquarters
2. 青田生产基地 / Qingtian Manufacturing Base
3. 松阳生产基地 / Songyang Manufacturing Base
4. 马来西亚生产基地 / Malaysia Manufacturing Base
5. 上海营销中心 / Shanghai Sales Center
6. 韩国营销中心 / Korea Sales Center

## 浙江青山钢管有限公司

ZHEJIANG TSINGSHAN STEEL PIPE CO., LTD.

营销中心地址：浙江省温州市龙湾区永中街道龙祥路2666号青山控股大楼A座10层  
Sales Center : 10th Floor, Tsingshan Building A, No.2666, Longxiang Road, Yongzhong Street, Longwan District, Wenzhou, Zhejiang Province, China

青田工厂地址：浙江省丽水市青田县温溪小峙工业区  
MFG Center : Xiaozhi Industrial Zone, Qingtian County, Zhejiang Province, China

营销热线 / Service Hotline : +86 4006727868

电话 / Tel : +86 577 86620888

网址 / Web : www.tsingshan.net

传真 / Fax : +86 577 86620889

E- mail : sales8@tsingshan.net (内贸 / Domestic )  
sales@tsingshan.net (外贸 / Export)

